



LIVIN HILL

ASSEMBLY INSTRUCTIONS & PARTS IDENTIFICATION

MODEL # 2253 - 54

ISABELLA 3 DOORS ACCENT CABINET AQUA FINISH

Parts key

No	Code	Qty	Description	No	Code	Qty	Description
1	2253-54P54	1 pc	Top	11	2253-54P07L	1 pc	Left Side Facing End Door
2	2253-54P51B	1 pc	Bottom Shelf	12	2253-54P07R	1 pc	Right Side Facing End Door
3	2253-54P53	1 pc	Front Frame	13	2253-54P07M	1 pc	Middle Door
4	2253-54P51L	1 pc	Left Side Facing Side Panel	14	2253P51H	4 pc	Side Panel Hinge
5	2253-54P51R	1 pc	Right Side Facing Side Panel	15	2253P07H	6 pcs	Door Hinge
6	2253-54P08V	1 pc	Vertical Partition	16	2253P02M	1 pc	Middle Leg
7	2253-54P08SL	1 pc	Left Side Shelf	17	2253P01L	5 pcs	Leveler
8	2253-54P08SR	1 pc	Right Side Shelf	18	2253P01D	1 pc	Door Catch
9	2253-54P38SL	1 pc	Left Side Back Panel	19	2253P01AT	1 set	Anti-Tip Kit
10	2253-54P38SR	1 pc	Right Side Back Panel				

Hardware Kit 2253-54P01

No	Code	Qty	Description	No	Code	Qty	Description
20	2253P08P	8 pcs	Shelf Pin	22	2253P01S	8 pcs	Wood Screw
21	2253P04	3 pcs	Knob w/ Screw				

PLEASE NOTE: Assembly requires two people. Follow directions step by step.

Step:01

Carefully lay out all pieces on a padded surface to prevent damage. Take extra care when removing the door unit from the carton. Doors must be secured so they will not fall open.

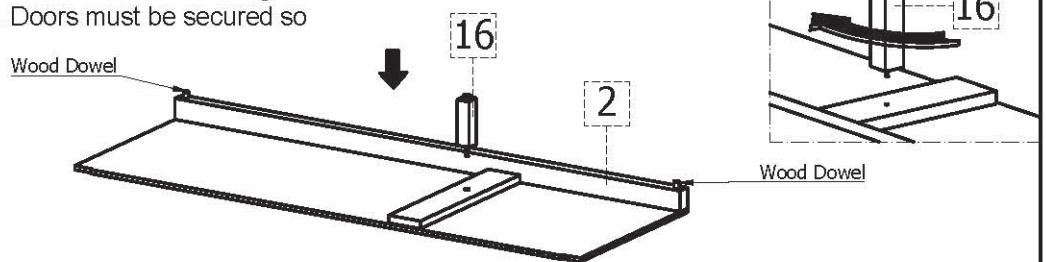

-Attach the middle support legs to the underside of the bottom shelf.

Step:02

- With the help of the second person, open the front frame assembly positioning the two side panels of the cabinet 90° perpendicular to the cabinet frame.

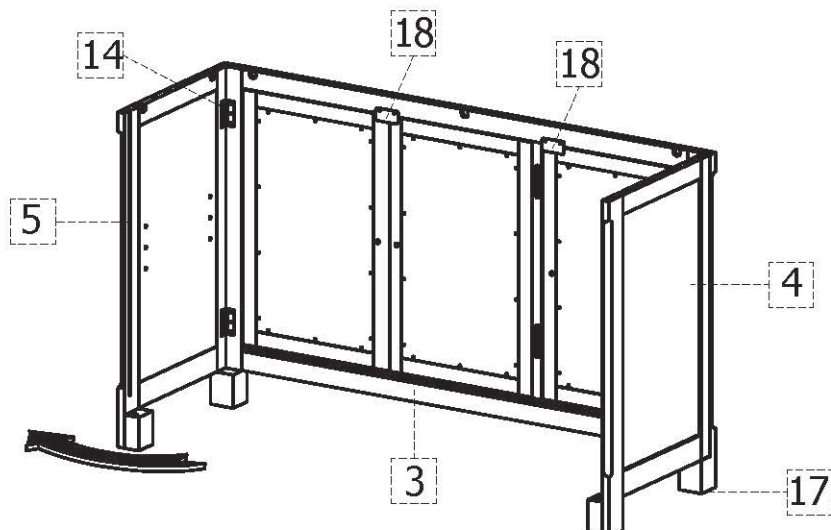



LIVIN HILL

ASSEMBLY INSTRUCTIONS & PARTS IDENTIFICATION

MODEL # 2253 - 54

ISABELLA 3 DOORS ACCENT CABINET AQUA FINISH

Step:03

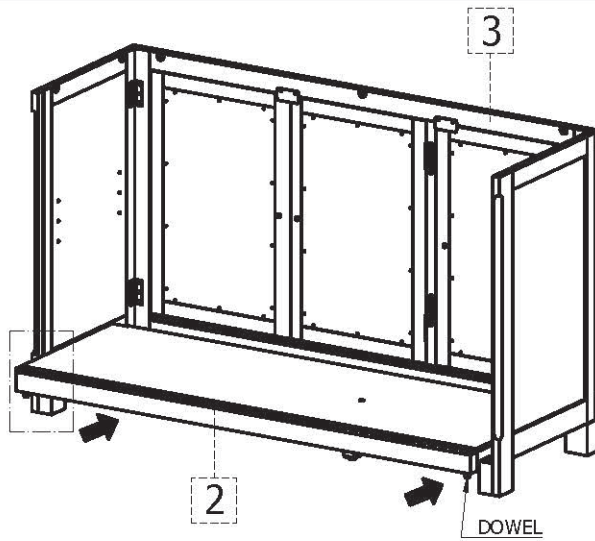
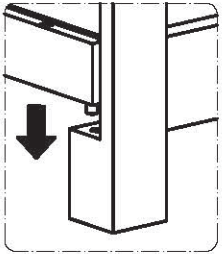

- Place the bottom shelf in position and lock the wood dowels into the receiving holes in the rear leg.

Step:04

- Insert the Vertical Partition by placing the tab on the panel into the receiver on the Front Frame and gently push down to lock into place. Make sure that the locking tab is in the opened position to insert into the bottom shelf.

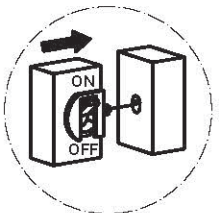
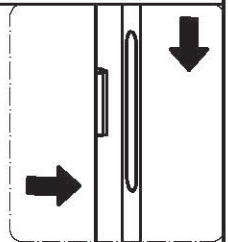
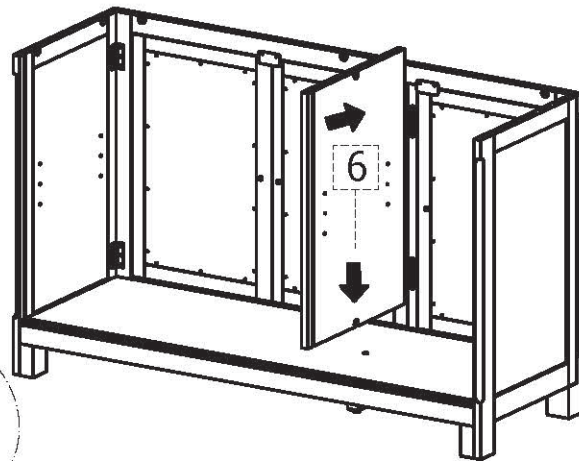

Tab in opened position

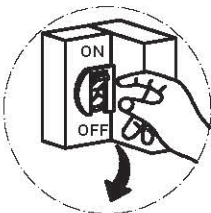

Pull tab down to lock



Tab in locked position

- Lock the tab (see diagram below) to secure the vertical panel to the bottom shelf.

Step:05

- Carefully insert the back panels into place making sure that the lock tabs are in the open position on the bottom of the back panel.
- Once in place, lock the tabs on the bottom.

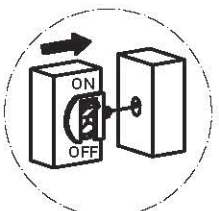
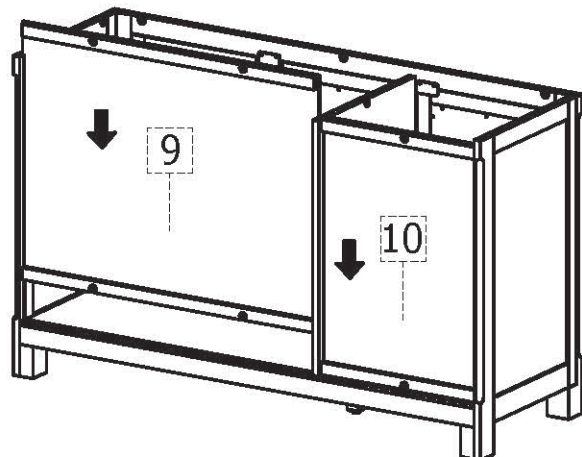

Tab in opened position

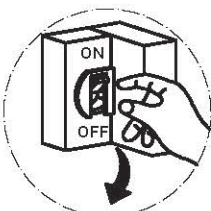

Pull tab down to lock



Tab in locked position



LIVIN HILL

ASSEMBLY INSTRUCTIONS & PARTS IDENTIFICATION

MODEL # 2253 - 54

ISABELLA 3 DOORS ACCENT CABINET CHAMPAGNE FINISH

Step:06

- Line up all the locking tabs in the open position
- With two people, carefully align the top in place making sure that the tab fits into the receiver portion on the top. Once firmly in place, lock the tabs.

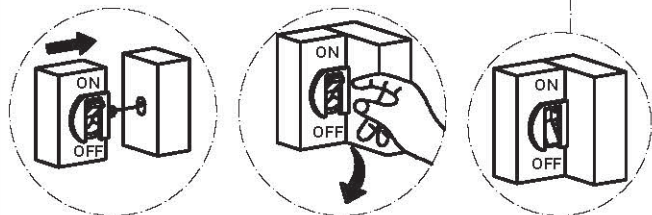

Tab in opened position

Pull tab down to lock

Tab in locked position

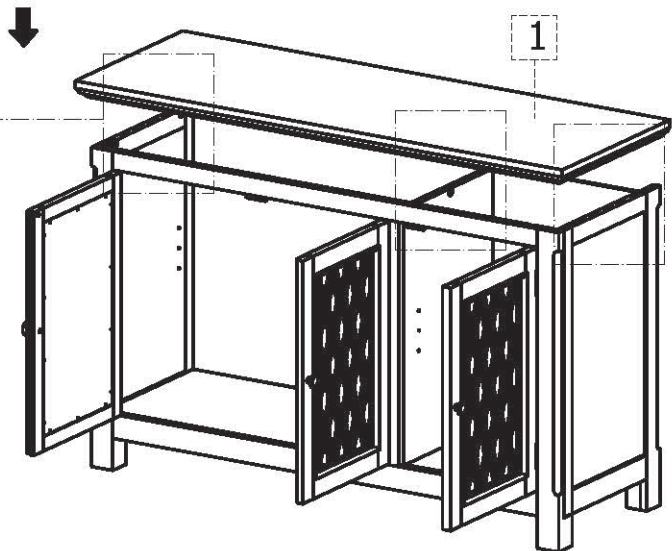

Step:07

- Install the shelves using the shelf pins. it is important to secure the shelf in place with the wood screws (See Diagram)
- Install the grip handle to fit the hand, not too tight or too loose.

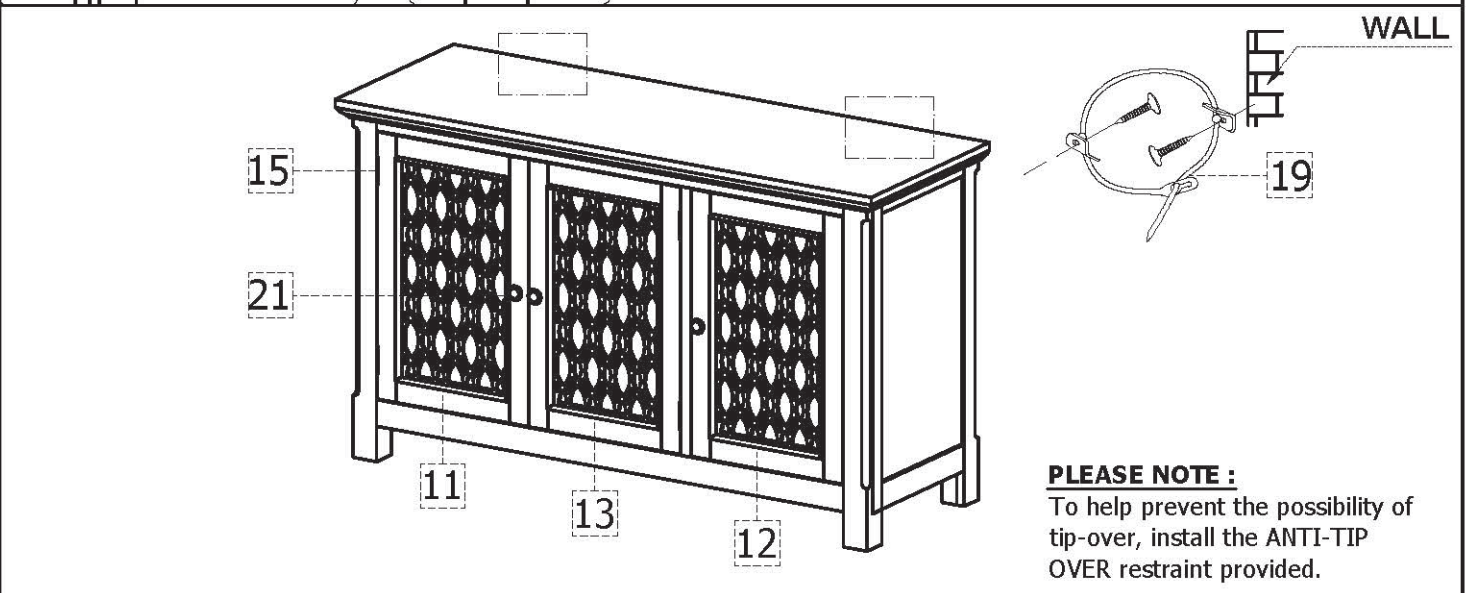
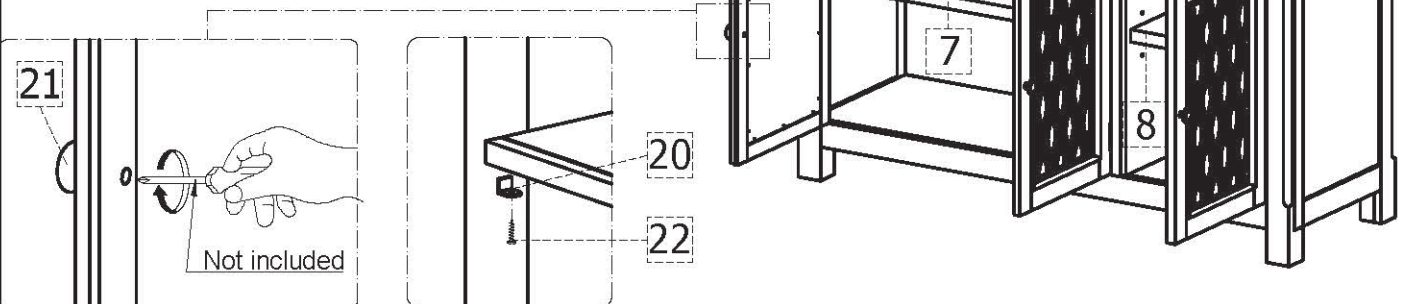

PLEASE NOTE :

To help prevent the possibility of tip-over, install the ANTI-TIP OVER restraint provided.