



LIVIN HILL

ASSEMBLY INSTRUCTIONS & PARTS IDENTIFICATION

MODEL # 2294 - 33KD

ARCHDALE 2 DOOR ACCENT CABINET GREY FINISH

Parts key

No	Code	Qty	Description	No	Code	Qty	Description
1	2294-33KDP54	1 pc	Top	8	2294-33KDP07L	1 pc	Left Side Facing Door
2	2294-33KDP51B	1 pc	Bottom Shelf				
3	2294-33KDP53	1 pc	Front Frame	9	2294-33KDP07R	1 pc	Right Side Facing Door
4	2294-33KDP51L	1 pc	Left Side Facing Side Panel				
5	2294-33KDP51R	1 pc	Right Side Facing Side Panel	10	2294KDP51H	6 pcs	Side Panel Hinge
				11	2294KDP07H	4 pcs	Door Hinge
6	2294-33KDP08	1 pc	Shelf	12	2294KDP01L	2 pcs	Leveler
7	2294-33KDP38	1 pc	Back Panel	13	2294KDP01D	1 pc	Door Catch
				14	2294KDP01AT	1 set	Anti-Tip Kit

Hardware Kit 2294-33KDP01

No	Code	Qty	Description	No	Code	Qty	Description
15	2294KDP08P	4 pcs	Shelf Pin	17	2294KDP01S	4 pcs	Wood Screw
16	2294KDP04	2 pcs	Handle w/ Screw	18	2294KDP01WD	2 pcs	Wood Dowel

PLEASE NOTE: Assembly requires two people. Follow directions step by step.

Step:01

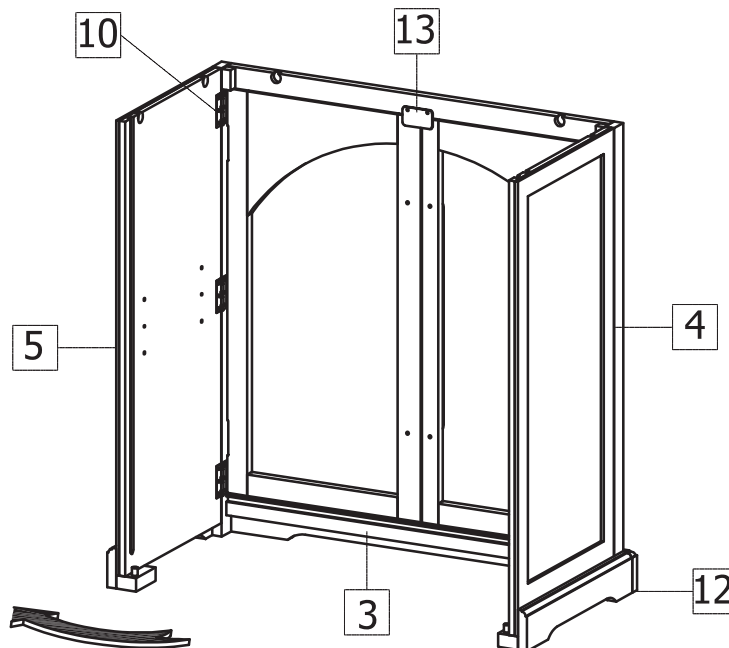

- With the help of the second person, open the front frame assembly positioning the two side panels of the cabinet 90° perpendicular to the cabinet frame.



LIVIN HILL

ASSEMBLY INSTRUCTIONS & PARTS IDENTIFICATION MODEL # 2294 - 33KD ARCHDALE 2 DOOR ACCENT CABINET GREY FINISH

Step:02

- Insert the wood dowels into the rear leg support

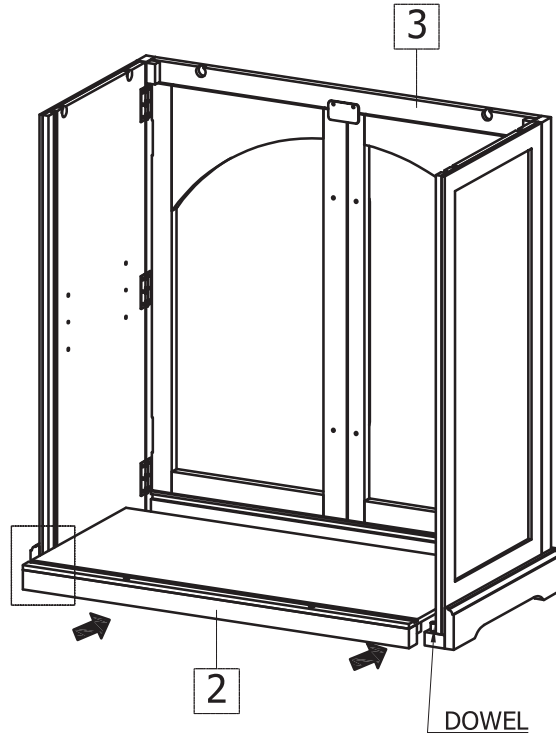
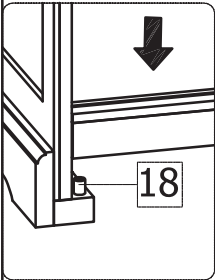

- Place the bottom shelf in position and lock the wood dowels into the receiving holes in the rear leg.

Step:03

- Carefully insert the back panels into place making sure that the lock tabs are in the open position on the bottom of the back panel.
- Once in place, lock the tabs on the bottom.

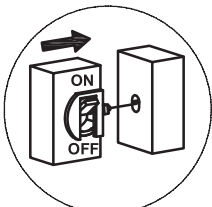
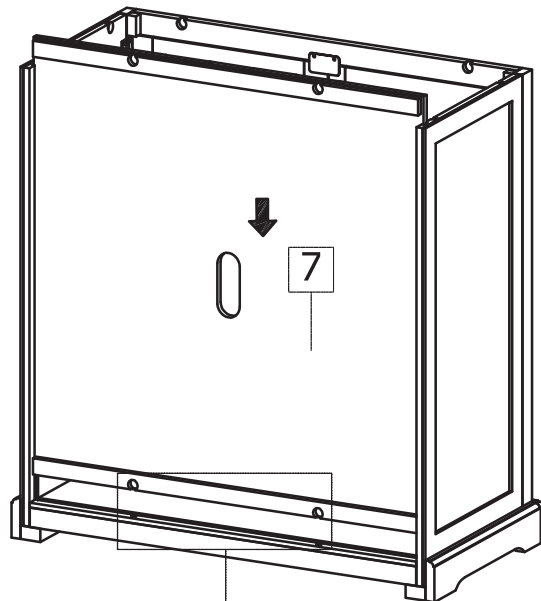

Tab in opened position

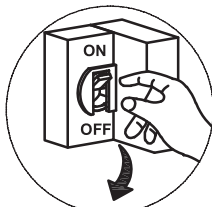

Pull tab down to lock



Tab in locked position



LIVIN HILL

ASSEMBLY INSTRUCTIONS & PARTS IDENTIFICATION

MODEL # 2294 - 33KD

ARCHDALE 2 DOOR ACCENT CABINET GREY FINISH

Step:04

- Line up all the locking tabs in the open position
 - With two people, carefully align the top in place making sure that the tab fits into the receiver portion on the top. Once firmly in place, lock the tabs.

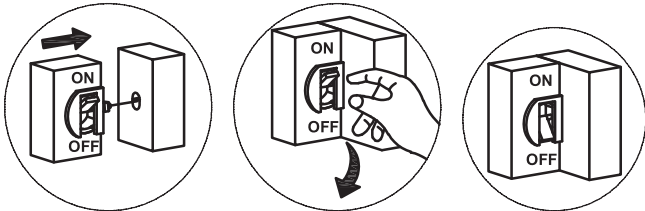

Tab in opened position Pull tab down to lock Tab in locked position

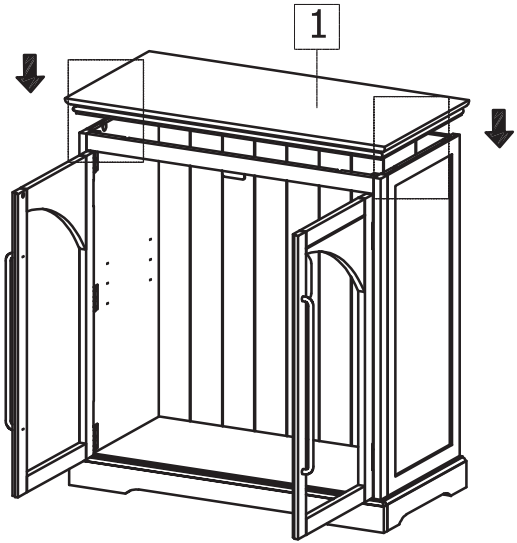

Step:05

- Install the shelves using the shelf pins. it is important to secure the shelf in place with the wood screws (See Diagram)
 - Attach the door pull with a Phillips screwdriver as shown.

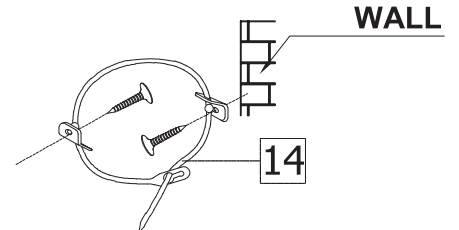
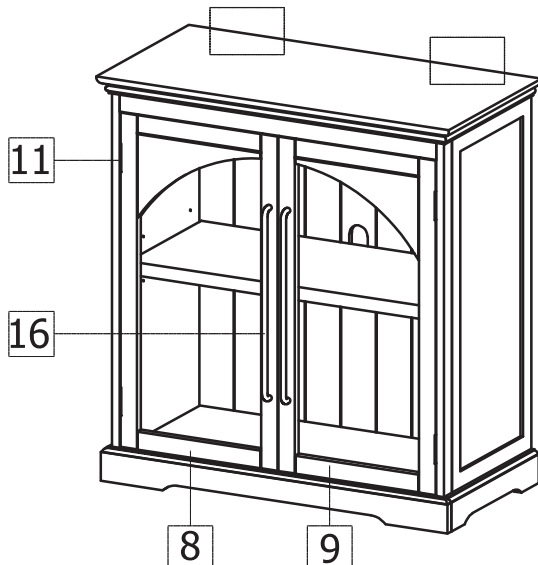
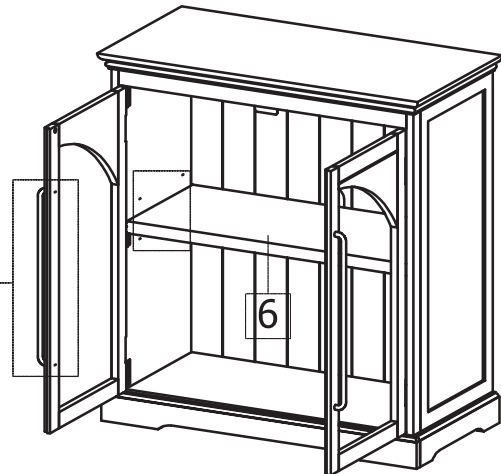
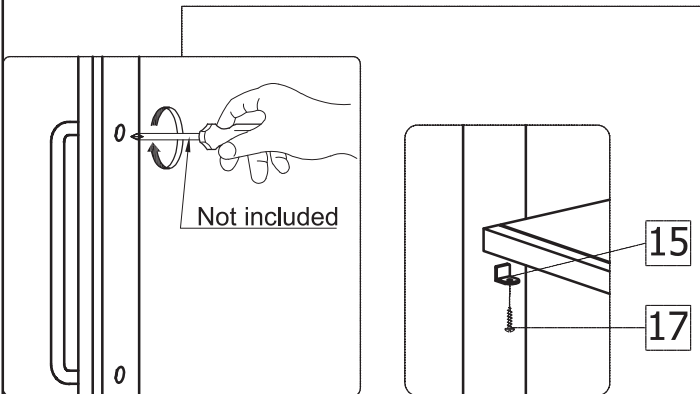

PLEASE NOTE :

To help prevent the possibility of tip-over, install the ANTI-TIP OVER restraint provided.